



## 1. Warm-up (Agilities / Footwork)

- (i) single steps
- (ii) double steps
- (iii) crossovers (face side ways, LEFT leg leads)
- (iv) crossovers (face side ways, RIGHT leg leads)
- (v) in, in, out, out
- (vi) hopscotch - double out, double in
- (vii) hopscotch - double out, single in

## 2. Dribbling Skills

Push Dribble: "The Silent Dribble"

Encourage athletes to keep the ball on their stick. Ball position changes as they go around the cones. In (i), ball moves from 2 o'clock to 12 o'clock before a turn. In (ii), the ball moves from 2 o'clock to 4 o'clock.

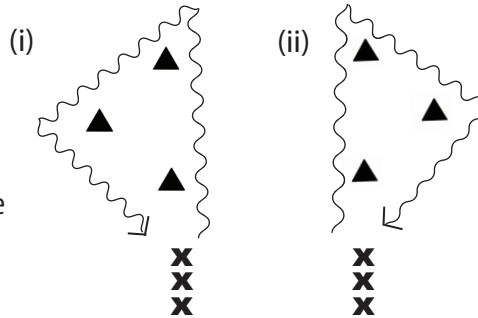

## 3. Passing & Receiving

Stationary push passing: "The Silent Pass"

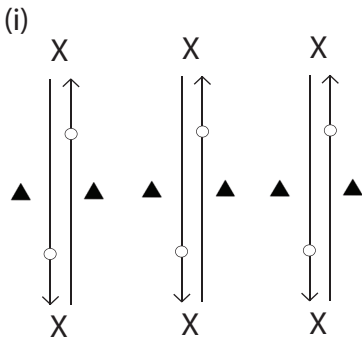

Athletes will be 7-10 yards apart.

a.) In Partners:

Place two cones like gates to help the athletes focus on making straight, accurate passes to their partner.

*Challenge:* Ask the athletes to count how many passes they can do in one minute.

b.) In groups of four, two on each side, after making pass, player runs to end of opposite line to keep drill continuous.

## 4. Skills Game

Hockey Volley ball

In two teams, each team from their own half tries to push pass the ball over the opposite team's endline while also "defending" their own endline.

- Ensure athletes make 2 passes amongst their team before sending ball to other team's endline
- Add an additional ball to increase movement of players and awareness

### 1. COACH TIPS

- break the athletes into two groups
- can use sticks on the ground or cones if you don't have agility ladders

### 2. COACH TIPS

- encourage tight curls around the cones keeping the ball on stick and close to cones
- in (ii), encourage the ball speed to be slowed down and let the feet move past the ball to make the turn easier

### 3. COACH TIPS

- Focus on one or two pointers for both the pass and the reception
- Passer: left shoulder faces partner and follow through should be towards partner
- Receiver: Faces partner square on with one foot slightly in front of the other. Receive ball in front of right foot with left hand pushed out to angle stick towards turf.

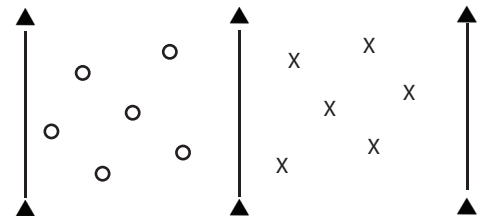



COACHING NOTES: Review the following coaching notes prior to the day of practice. Use these tips throughout the drills to help players progress.

## Agilities / Footwork

(i) **single steps** - one foot alternating in each space between sticks

(ii) **double steps** - both feet touch down, one at a time, in each space leading with right foot once through circuit, then leading with left leg

(iii) **in, in, out, out** - face forwards start with feet outside the first rung then touch both feet in the first rung, one at a time, then both feet outside the second rung, one at a time, then repeat.

(iv) **hopscotch** - double out, double in - start with both feet outside the first rung then hop so both feet land in the first rung then land outside the second rung, then inside the third rung, etc. All are two-footed hops.

(v) **hopscotch** - double out, single in - start with both feet outside the first rung then hop on right foot in the first rung, then hop both feet at the same time outside the second rung. Then, hop left foot only in the third rung, then both feet outside the fourth, etc.

(vi) **crossovers** (face side ways with right leg closest to stick, LEFT leg leads) - left leg crosses over right leg so feet alternate landing in the rungs

(vii) **crossovers** (face side ways with left leg closest to stick, RIGHT leg leads) - right leg crosses over left leg so feet alternate landing in the rungs

## Dribbling Skills

Push Dribble: "The Silent Dribble"

Make sure players slow down the ball as they approach the cone. This will help them maintain possession of the ball as they turn around the cones. Try to encourage the players to keep the ball on their stick as much as possible.

## Passing & Receiving

**Receiver**

- Square up feet so both toes are pointing towards partner. The player should receive/trap the ball in front of their RIGHT foot. Receiver may stand with feet square or have one foot slightly in front of the other (which ever position is more comfortable). The athlete may want to think about absorbing the ball onto their stick. Have the stick angle facing towards the turf by pushing the top hand (Left hand) away from their body.

**Passer**

- LEFT shoulder facing partner. Feet are shoulder width apart and hands are 10-12" apart (LEFT hand at the top of the stick & RIGHT hand at the bottom of the stick grip). Place the ball out in front of the RIGHT foot (10-12"). Place stick on the ball and push the ball towards partner - transferring weight from right foot to left foot. Follow through towards partner.

- Remember proper ball position (not too far ahead or too far behind) and correct follow through (straight towards partner) will help determine the accuracy of the pass. This should be the focus prior to how hard the athlete can pass the ball.

- Remind the players that the stick starts and stays on the ball for the push pass (thus making it SILENT)

\*\* Place cones about a stick length apart (see diagram) so that the players can try and pass through as they pass to each other. This will provide them with a target to keep the pass straight. Encourage athletes to bend at the knees to generate power with their legs.

## Skills Game

Hockey Volleyball

Encourage lateral passes within the team prior to sending the ball over the half way line to encourage the movement of the other team in order to create space. The kids can move around within their side of the grid to pass and receive. This game can be played in multiple grids in 2 v 2 or 3 v 3 to encourage more touches on the ball. Encourage the kids to keep the ball on the ground and use only push passes (silent passes) to send the ball to the other side.



## 1. Warm-up (Defensive Footwork)

Focus on FOOTWORK! Use two grids to accommodate all players.

\*\*perform first without stick, then repeat with stick

- (i) Shuffles (facing the line of players)
- (ii) Cross-overs (facing the line of players)
- (ii) Running (turn feet to point in the direction they are moving)

Encourage players to have LEFT hand only on stick. The stick stays on the ground angled towards the turf at all times.

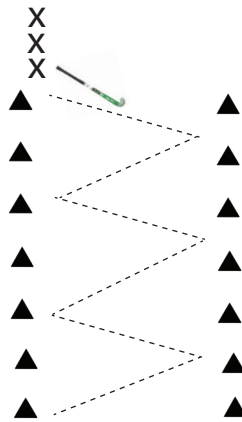

## 2. Defensive Skills (Channelling)

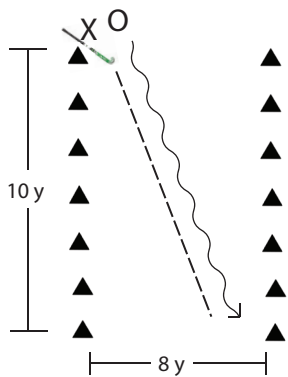

Objective: To move offensive player towards sideline or team mate in order to delay the play or encourage a double team.

X = defense

O = offense

Complete drill without a ball first.

Each athlete will dribble 3x and then channel 3x with a ball.

### 1. COACH TIPS

- Demonstrate the drop step with inside foot when changing directions to keep kids moving on 45 degree angles
- for (i) and (ii) the players should face the line of players
- stick stays in same position (no reverse stick is used) to protect feet

### 2. COACH TIPS

Defender: Keep feet behind ball, stick low and protecting feet and keep stick open facing far cone (not reaching across to try and tackle). \*no tackling\*

## 3. Passing and Receiving on the Move

Passing in Shuttles (groups of 4-5)

- (i) Have the players dribble a few steps forward and while in motion pass the ball to the player at the front of the opposite line and then continue their run across to join the back of the opposite line
- (ii) The players dribble to the right on a 45 degree angle for 2-3 steps and then pass and join the back of the opposite line. Remind the athletes to bring the ball to 12 o'clock before making the pass and to keep their body weight centered (not fading away).
- (iii) Repeat drill in opposite direction.

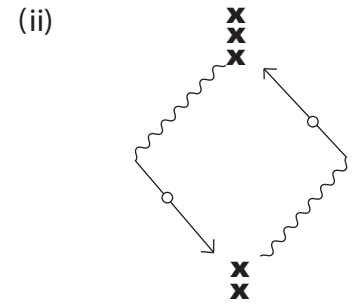
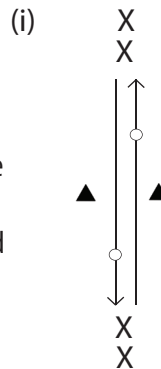

## 4. Skills Game (Wall Ball)

X1 is the "pusher" and everyone else is the "wall"

X1 tries to push pass the ball past the "wall of players" to score a point. Players in the wall and X1 can move laterally between their respective cones. If a player in the wall traps the ball, they then become the "pusher."





COACHING NOTES: Review the following coaching notes prior to the day of practice. Use these tips throughout the drills to help kids progress.

## Defensive Footwork

- (i) Shuffles (facing the line of players) - encourage a low body position and the left hand to be as low as possible and just above the left foot so as to keep as much of the stick covering the feet as possible.
- (ii) Cross-overs (facing the line of players) - when crossing over diagonally back to the right: the left foot crosses over the right leg. Then, use the left foot to drop step back on a diagonal and have the right foot cross over the left foot when crossing over left.
- (ii) Running (turn feet to point in the direction they are moving) - body faces forward in the direction that you are moving. Still use the drop step so stick stays in strong stick position in front of feet. Remember: the stick stays on the ground!

## Defensive Skills (Channelling)

**Defender:** Remember that the objective is to move the attacker in another direction NOT to tackle. The defender needs to keep his/her feet behind the ball and with the left hand only on the stick, keep it low and in front of the left foot. When channelling, the defender should run with toes facing the direction they are moving and should not shuffle in case (in a game) the speed of the attacker is really fast. The defender's stick needs to stay protecting his/her feet at all times not reaching in front of the attacker to try and tackle.

**Attacker:** Attacker initially dribbles on a diagonal to the opposite corner of the grid. On a progression of the drill, the attacker can change speed - slowing and speeding up every few steps - to help the defender work on keeping their stick down and not over-committing to allow the attacker to pull back and go around.

## Passing and Receiving on the Move

- (i) Put players into 2 small groups (shuttles will be about 12-15 yards apart)
  - First player push dribbles and rolls the ball off the stick to pass player at front of opposite line, receiver repeats in opposite direction
  - Players will follow their pass to join the back of the opposite line
  - On the reception: players can move their RIGHT hand lower down the stick - this will help receive on the move

*Challenge:* add a second ball to give the players for touches
- (ii) Changing the angle of the dribble and pass - dribble slightly to the right. Before making the pass move the ball from 2 o'clock to 12 o'clock
- (iii) Dribble slightly to the LEFT. Let your feet move slightly past the ball. The ball position drops from 2 o'clock to 4 o'clock. Roll the ball off your hockey stick to pass the ball to teammate.



### 1. Warm-up (Agilities/Footwork)

- (i) plant & push on change of direction (face forward, hand touches each cone)
- (ii) plant & push without touching cones
- (iii) studder step at each cone & accelerate to next cone
- (iv) figure 8's with feet around cones
- (v) left and right foot pivots (right foot pivot at left cone, left foot pivot at right cone)

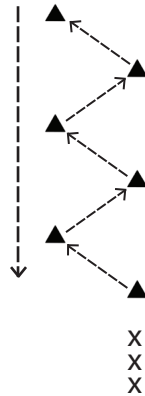

### 2. Dribbling Skills - Draws RIGHT



a.) Draws left and right

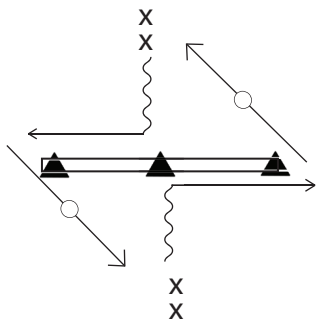

b.) Continuous Drill:

- (i) Draw right at the board
- (ii) Fake left over top of the ball (Drawing a "C" around the ball, keeping stick on the ground) and then draw right

### 1. COACH TIPS

- encourage a low body position
- use quick change of direction
- bend at the knees

### 2b. COACH TIPS

- (i) have players dribble toward middle cone and keep stick on ball for the draw. Encourage the draw from left to right to come past their right foot (really wide).
- (ii) have the players start their "C" or fake a few steps earlier before the board to give time for fake AND draw right
- \*\* After draw, have the ball come back to 12 o'clock to make pass across body easier.

### 4. Defensive Skills

(i) Flapper Drill (no ball)

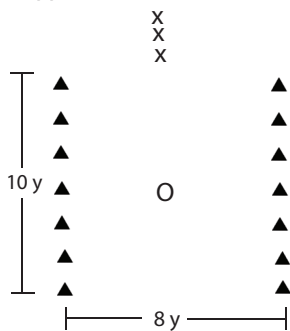

(ii) Shadowing Drill (with ball)

O = offense  
X = defense

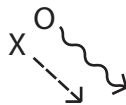

Do this skill over 25 yards. Change the ball carrier at each end.

### 5. Skills Game

MINI GAME: make a field about 25 x 30 yards using two cones (1 yard apart) per goal. Have multiple goals spread randomly throughout the grid. Teams can score in any goal just not the same goal twice in a row.

Variations: (1) goal = "shoot" through the cones (2) goal = pass to teammate through cones (3) goal = dribble with control through cones



COACHING NOTES: Review the following coaching notes prior to the day of practice. Use these tips throughout the drills to help kids progress.

## **Dribbling Skills - Draws Left and Right**

### **a.) Draws left and right:**

(i) In partners - a ball each. Athletes will stand one on each side of the line of 2-4 cones. The cones will be the length of a stick. X1 and X2 will be doing the drill at the same time.

- players will stand with feet shoulder width apart, keeping knees bent
- the ball will be a stick length away from their feet
- the top of the stick will be pointing at their belly button

a) pull the ball from one end of the cones to the other. Start with the ball at the RIGHT end of the cones and use the strong stick to pull/draw the ball across to the LEFT. Keep the stick on the ball and transfer weight from (R) to (L).

b) Once the ball is at the LEFT end of the cones, roll your stick over the ball (protecting the ball) allowing the stick to spin in the right hand. Now you have your reverse stick on the ball. Use the reverse stick to pull the ball back to the RIGHT. **\*\*REPEAT\*\***

**\*\*** See how many times the athletes can do this in 1 minute. The goal is to improve their own score! **\*\***

### **b.) Draw RIGHT with progressions: \*\*Only use two balls\*\***

(i) Have players work through movements without a ball first. Practice transferring of body weight from left to right. The drills is continuous. Players will start from both ends of the drill. Players at the start of each line will dribble forward towards the cone. Moving the ball from 2 o'clock to 12 o'clock (slightly in front of their left foot). As the players approach the cone, they will draw the ball to their right. The stick will move over the ball while pulling the ball with their reverse stick to their strong stick. The weight transfer is left to right. They dribble forward and pass to the next person in line. (Make sure ball is moved to 12 o'clock before making pass)

(ii) Same as above but the players draw the letter "C" on the ground and over the ball before they draw. They must start to draw the "C" a little earlier than they would do the normal pull to give them time and prevent them from running into the board.

## **Defensive Skills: Flapper Drill and Shadowing Drill**

(i) Flapper drill -played without a stick

- "o" = defender
  - responsible for closing time and space, needs to keep elbows tucked in at all times
  - working on footwork to prevent "X" from getting past them
  - can touch "o" with hands but is not allowed to extend arms
- "X" = attacker
  - trying to run past "o"
  - encourage them to have a change of pace and create their own space
  - run forwards on angles instead of "dancing around" at the top of the grid

(ii) Shadowing Drill - Give each athlete the opportunity to dribble with the ball. This can be done over 25 yards

- "O" = offence
  - dribbles the ball in any direction moving forward
- "X" = defence
  - shadows the ball carrier using their defensive footwork
  - defender must keep their stick on the ground (preferably using only their left hand)
  - not trying to tackle

**\*\***Keep your body weight on your toes or balls of feet, think "Happy feet!"



## 1. Warm-up Game, Agilities or Footwork

### 2. Passing & Receiving

Receiving over the LEFT & RIGHT shoulder. \*See Diagram Right

- (i) receive over (R) shoulder x2
- (ii) same but increase pace x2
- (iii) same but draw (R) after reception x2
- (iv) receive over (L) shoulder x2
- (v) same but increase pace x2

\*Have feet facing forward on pass and reception. Make sure ball is passed away from the receiver's feet.

### 3. Passing & Receiving

Focus : Receptions over the RIGHT shoulder

- Encourage a change of pace on leads
  - Practice both an open and closed pivot around the cone
- OPEN --> you can always see the passer  
CLOSED --> you can not see the passer until the last second

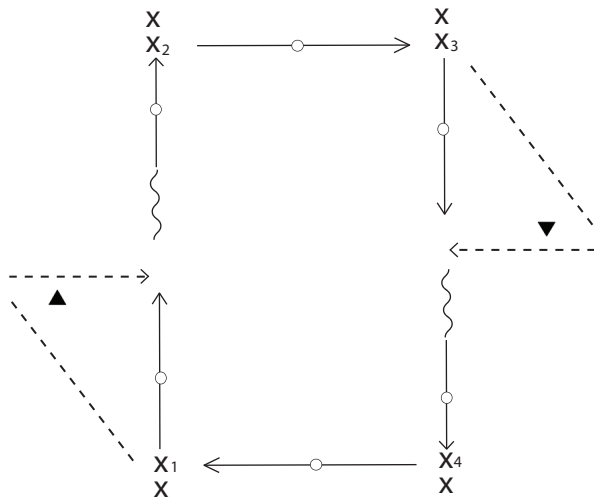

## 2. DRILL DIAGRAM

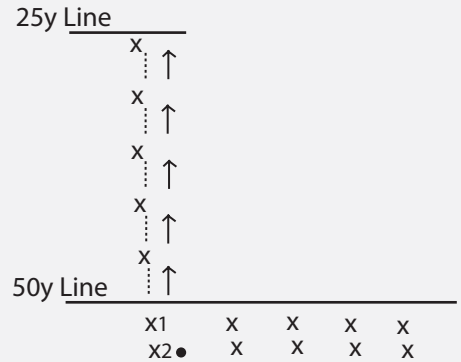

## 3. COACH TIPS

Encourage the players to watch the ball once it is passed all the way on to their stick. Lead with head of stick low to the ground to help with reception.

## 4. Defense: Block Tackle

- (i) Stationary block tackle (aka flat stick tackle)
  - 20 seconds on / 20 seconds off (repeat 3 times)
- (ii) See Drill to the Right -->
  - X1: somewhat of a passive ball carrier to allow O1 to work on the timing of the tackle.
  - Keep the drill continuous X1--> O1, O1--> X1
  - X1 is trying to dribble through the goal on the opposite side of the grid
  - O1 is closing time and space on the ball carrier and makes the tackle as X1 changes the angle of their dribble.

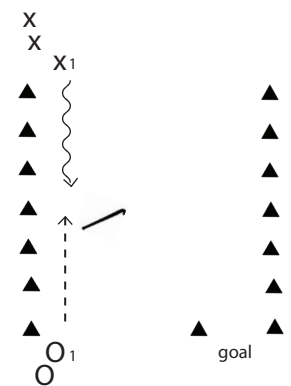

## 5. Skills Game

MINI GAME: make a field about 25 x 30 yards using two cones (1 yard apart) per goal. Have multiple goals spread randomly throughout the grid.

Teams can score in any goal just not the same goal twice in a row.

Variations: (1) goal = "shoot" through the cones (2) goal = pass to team mate through cones (3) goal = dribble with control through cones



COACHING NOTES: Review the following coaching notes prior to the day of practice. Use these tips throughout the drills to help kids progress.

## **Dribbling Skills**

Refer to the last sessions notes on how to teach the draw right. From observation, please make sure the players change the ball position as they approach the board. This will help with the execution of the skill.

## **Passing and Receiving: Receptions over Left and Right Shoulder**

Put players in pairs (one ball between two). The drill will take place over 25 yards.

- (i) X1 starts with their back to X2. X2 sends a push pass to the right side of X1. X1 will receive with a reverse stick over the right shoulder. X1 will trap the ball and then move forward, leaving the ball for X2 to send another pass. This should happen 3-5 times over a 25 yard distance.
- (ii) Same as above; except increase the speed of the pass
- (iii) Same as above, except after reception, step forward with left foot, drop step with right foot (turning to your right), draw the ball across your body (draw right) and pass back to X2.
- (iv) Same as (i); except X1 will receive strong stick over their left shoulder
- (v) Same as above; except increase the speed of the ball

## **Passing and Receiving: Receptions over the Right Shoulder**

This is a continuous drill, allowing the players to get maximum touches in a short period of time.

X1 and X3 will start at the same time. They will make their lead around the cone. As soon as they get to the cone, the next person in line will send a paced through pass so X1 and X3 are able to make an upright reverse stick reception over their right shoulder. X1 and X3 will then dribble and send a through pass to X2 and X4. X2 and X4 will send a square pass to the next person in line. Players will follow their pass and repeat the drill.

OPEN PIVOT --> Plant RIGHT foot at the cone, open up towards passer (turn to your left) and continue your lead. Should always see the passer.

CLOSED PIVOT --> Plant LEFT foot at cone. Body is closed to passer. Look over RIGHT shoulder for eye contact.

## **Defensive Skills: Block tackle**

- (i) Stationary - 20 seconds on and 20 seconds off (repeat 3 times). Keep body behind the stick and repeatedly lunge to 12 o'clock, 1 o'clock, 2 o'clock and 3 o'clock - always bringing the stick back to the middle of your body between lunges. Keep weight on toes.





## 1. Warm-up Game / Agilities / Footwork

- (i) single steps
- (ii) double steps (change leading leg)
- (iii) crossovers (face side ways, LEFT leg leads)
- (iv) crossovers (face side ways, RIGHT leg leads)
- (v) in, in, out, out
- (vi) hopscotch - double out, double in
- (vii) hopscotch - double out, single in

## 2. Dribbling Skills - Curls LEFT / Strong Stick

Continous drill. The first person in each line will start with a ball.

As players progress, minimize the number of steps they take while curling.

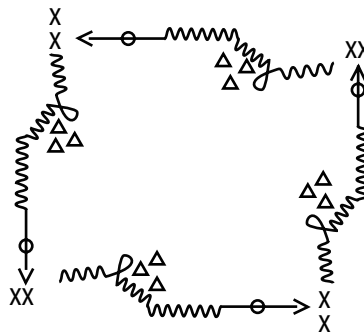

## 3. Passing & Receiving

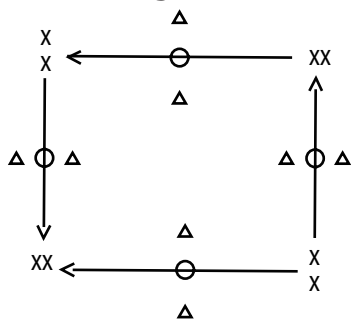

Focus : Receptions from left to right (pass and follow your pass)

There will be 2 balls going at once. They will start in opposite corners.

The players receiving the ball will watch the ball onto their sticks, letting the ball cross their body on the reception. Make sure that the player receiving the ball is facing towards the passer and their feet are facing straight ahead.

## 4. Defense

Focus: Stay in Contention

"X" = defender

- always keep themselves between ball carrier and the goal
- works on quick defensive footwork & low body position

"O" = attacker

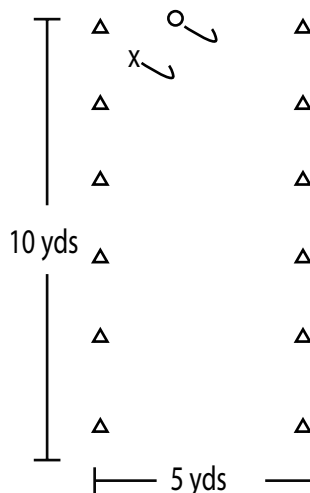

## 1. COACH TIPS

Use player sticks on the ground set up like a ladder on the ground. Use each space between the sticks like a rung of a ladder for each agility. See coaches tips attached.

## 2. COACH TIPS

Make sure the players start dribbling to the left of the cone and change the ball position from 2 o'clock (dribbling position) to 12 o'clock so the ball is out in front and it is easier to curl.

## 5. Skills Game

MINI GAME: make a field about 25 x 30 yards using two cones (1 yard apart) per goal. Have multiple goals spread randomly throughout the grid. Teams can score in any goal just not the same goal twice in a row.

- Variations: (1) goal = "shoot" through the cones
- (2) goal = pass to team mate through cones (3)
- goal = dribble with control through cones



COACHING NOTES: Review the following coaching notes prior to the day of practice. Use these tips throughout the drills to help kids progress.

## Dribbling Skills

Focus: Curl LEFT or strong stick curl.

Player will dribble to the LEFT of the cones. The ball position will move from 2 o'clock to 12 o'clock - in front of the left foot. RIGHT foot will step past the ball to protect the ball from the defender. Drop step with the LEFT foot - body is now between the ball and the defender. Make an arcing shape with the ball, keeping it on the strong stick and turn 180 degrees.

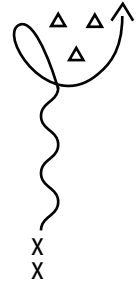

The curl allows you to maintain possession as well as eliminate a defender.

## Passing and Receiving

Focus: Reception from LEFT to RIGHT

After receiving the ball, step towards your target and make the next pass. After making your pass, follow your pass to the next corner of the square.

Challenge: To encourage accuracy of passing, add cones as gates for players to pass through

- Encourage players to minimize their footwork on the push pass.
- Minimize touches on the ball.
- Drop Right hand to help with the reception.

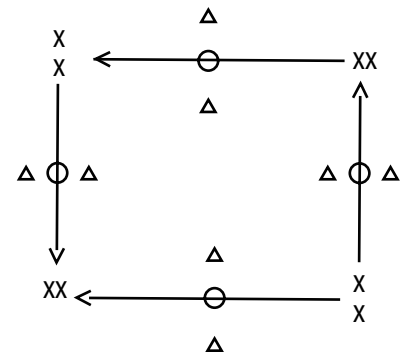

## Defensive Skills

Focus: Staying in Contention

"X" have LEFT hand only on the stick - keeping your stick on the turf. Make sure the stick angle is facing towards the turf.

"X" can start a step and stick length away from "O"

"X" wants to dictate the direction that "O" dribbles - use body to angle the ball carrier

"O" focus on change of pace and a quick change of direction when dribbling.

\*\*\* Coaches this is very similar to shadowing!



## 1. Warm-up Game / Agilities

## 2. Stationary Passing: The Sweep Hit

Have players practice their sweep hit against the cement wall about 10 yards away.

Break down of the sweep hit will be found on the attached "Notes Sheet"

If players have already had coaching and practice with this skill, they can skip the part where they are on their knees.

Make sure the ball is rolled straight ahead and the player's learn the proper footwork.

## 3. Passing & Receiving

Passing the ball into space for a teammate.

Encourage the player running into space to have their stick close to the ground but keep their toes facing forward.

Pass and follow your pass.

Encourage players to send a paced pass into space.

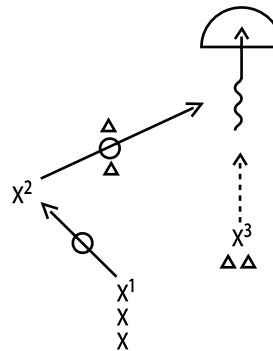

## 4. Defense

Focus: Double Team

Same as the channelling drill, except another defender is added for the double team.

X2 will close time and space towards the RIGHT side of the cones when "O" is being channeled. X2 will make a low flat stick tackle with stick angle facing the turf. X2 should be yelling "double" so that X1 knows they have support coming.

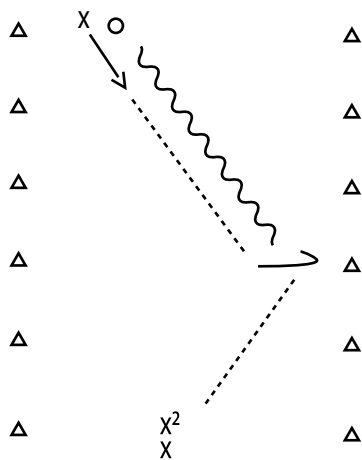

Make sure X2 (defender) does not get in the double team position too early. The timing of the tackle is important.

## 2. COACH TIPS

Ball position can help improve accuracy. If the ball is too far in front, the ball may travel too far left and if the ball is too far behind, the ball may travel too far right.

## 3. COACH TIPS

Ensure that X2 sends a paced pass on an angle that is ahead of X3. X3 should keep toes facing forward and continue to be in motion as they receive the pass. They will then turn their feet around to make their pass or shot into the net.

## 5. Skills Game

MINI GAME: make a field about 25 x 30 yards using two cones (1 yard apart) per goal. Have multiple goals spread randomly throughout the grid. Teams can score in any goal just not the same goal twice in a row.

Variations: (1) goal = "shoot" through the cones (2) goal = pass to team mate through cones (3) goal = dribble with control through cones



COACHING NOTES: Review the following coaching notes prior to the day of practice. Use these tips throughout the drills to help kids progress.

## **Stationary Passes: Sweep Hit**

Progressions:

(i) Players begin on knees: LEFT shoulder facing the cement wall. The ball is in front of the LEFT knee, about a stick length away (2.5 feet). Two hands are at the top of the stick, together. The stick remains on the ground at all times with the exception of the follow through. Sweep the stick along the ground making contact with the ball with the shaft of the stick - avoid contact with the head of the stick.

(ii) Players stand up. LEFT shoulder facing the cement wall, about one step away from the ball also, diagonally back from the ball. Players can place stick on the ground. Step towards the ball with LEFT foot, keeping the stick on the ground. Sweep stick along ground, bending at the knees (low body position), contacting the ball with shaft of stick.

(iii) Same as above - except add a slight roll of the ball straight ahead (towards cement wall or partner) before making contact with the ball. Use the footwork sequence of L/R/L. Left foot straight ahead, right foot behind (it pulls you away from the ball). Left foot towards the ball. Keep stick on the ground.

## **Passing and Receiving**

Focus: Sending a pass into space

X1 will send a push pass to X2. X2 will send a paced pass through the cones into space for X3. X3 will receive the ball on the move, dribble and then take a shot at goal.

Rotation --> players will follow their pass: X1 to X2, X2 to X3, X3 to X1

To challenge the players, only have one athlete start in the X3 spot. Set up double cones, have X2 run and touch the cones prior to becoming X3. Once X3 touches the cone, she picks up the space pass.

You will want to set up two groups for this drill. They will get more repetitions. Set up the drill over 25 yards.

## **Defensive Skills**

Focus: The Double Team

X1 needs to channel "O" right to X2. X1 and X2 need to form a around "O".

Make sure all players get to perform in all three positions. You may need to have two grids going at once.



## 1. Warm-up Game / Agilities

## 2. Dribbling & Passing

Focus: Curl LEFT and pass

X dribbles toward the board, curls LEFT in front of the board (which is acting like a defender) and sends a push pass to their teammate. This is completed two more times and the last player shoots on net. Follow your pass. The next player in line starts to dribble as soon as the first pass is made.

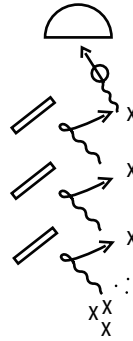

## 3. Passing & Receiving

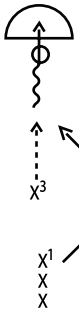

Focus: Upright reverse stick reception

Passing the ball into space for a teammate.

Encourage the player running into space to have their stick on the ground.

The pass into space is a paced push pass. Players follow their pass.

## 4. Passing: Sweep Hits

In the shuttle format.

Players will pass and follow their pass.

This is a progression from last week. Players will roll the ball and use proper footwork L/R/L

- Left foot towards ball
- Right foot behind (pulls you away)
- Left foot straight ahead

Keep stick on ground - contact ball with shaft of stick

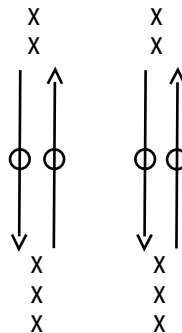

## 5. Skills Game

MINI GAME: make a field about 25 x 30 yards using two cones (1 yard apart) per goal. Have multiple goals spread randomly throughout the grid. Teams can score in any goal just not the same goal twice in a row.

Variations: (1) goal = "shoot" through the cones (2) goal = pass to team mate through cones (3) goal = dribble with control through cones

## 2. COACH TIPS

You can use a line of cones instead of boards. The boards are "defenders" and you use the curl to maintain possession.

## 3. COACH TIPS

Have X3 watch the ball as it is released from X2's stick and all the way onto their stick for the reception. Ensure X3 has their stick angled slight towards the turf. X3 should receive the ball at 12 o'clock in front of their body.

Make sure X2 sends a paced pass and not too hard.

## 4. COACH TIPS

Remind players to follow through towards their target and that ball position will affect which way the ball goes.

If the ball is too far in front of them, the pass may go too far left, if the ball is too far behind them, the ball may go too far right.



**Victoria Junior Field Hockey Association**

[www.victoriajuniorfieldhockey.ca](http://www.victoriajuniorfieldhockey.ca)

## **UNDER 10 - LESSON PLAN #7 - NOTES**

---

COACHING NOTES: Review the following coaching notes prior to the day of practice. Use these tips throughout the drills to help kids progress.

### **Dribbling and Passing**

Focus: Curl LEFT and pass

Player will dribble to the LEFT of the cones. The ball position will move from 2 o'clock to 12 o'clock - in front of the left foot.

RIGHT foot will step past the ball to protect the ball from the defender. Drop step with the LEFT foot - body is now between the ball and the defender. Make an arcing shape with the ball, keeping it on the strong stick and turn 180 degrees.

The curl allows you to maintain possession as well as eliminate a defender.

### **Passing and Receiving**

Focus: Sweep Hits

X1 will send a push pass to X2.

X2 will receive and send a paced pass through the cones into space for X3. X3 will receive with an upright reverse stick, get the ball to their strong stick as quickly as possible. X3 will dribble and take a shot on goal.

Rotation --> players will follow their pass: X1 to X2, X2 to X3, X3 to X1

To challenge players, only have one athlete start in the X3 position. Set up double cones, have X2 send the paced pass into space, then run and touch the double cones prior to becoming X3. Once X3 touches the cones, she can pick them up the pass that has been sent into space.



## 1. Warm-up Game / Agilities

### 2. Dribbling Skills

Focus: Indian Dribbling

(i) Stationary: Review practice plan #3 Drill 2 (i) - Draws left and right.

Each player has a ball - standing with feet shoulder width apart. The ball is out in front, almost a stick length away from the body. The players knees are bent and they are tapping the ball back and forth from strong stick to reverse and reverse to strong stick. Repeat.

(ii) On the move: Progression from stationary. Indian dribbling on the move over 15-25 yards in a straight line and then on different angles.

### 3. Passing & Receiving

Focus: Strong stick reception on the move

Roll ball off hockey stick for pass.

Ball position at time of pass is at 12 o'clock.

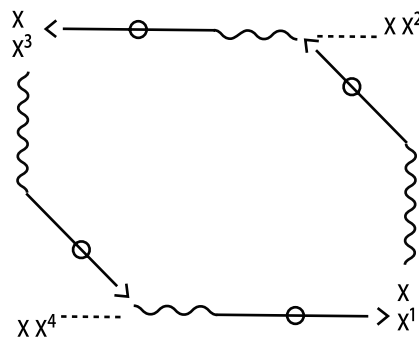

### 4. Passing & Receiving

Focus: Upright Reverse stick reception on the move

Strong stick pass: get feet around

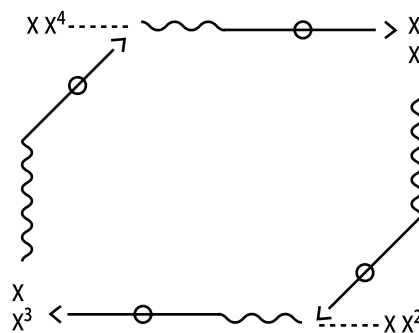

### 5. Skills Game

MINI GAME: make a field about 25 x 30 yards using two cones (1 yard apart) per goal. Have multiple goals spread randomly throughout the grid. Teams can score in any goal just not the same goal twice in a row.

Variations: (1) goal = "shoot" through the cones (2) goal = pass to team mate through cones (3) goal = dribble with control through cones

### 2. COACH TIPS

When going to the reverse stick, the stick should roll in the right hand so that the right wrist does not turn over. The stick spins in the right hand.

### 3. COACH TIPS

Encourage players to keep their stick touching the ball as much as possible and to send their pass slightly in front of the next player.

Players running onto a pass should have their toes facing forward and their stick close to the ground, ready for a reception on the move.

### 4. COACH TIPS

Players need to slow the ball speed down just before they make their pass and focus on "getting their feet around."

Players receiving should watch the ball as it is passed right until the ball touches their stick. The ball is easier to receive when passed at a good reach's distance in front.



**Victoria Junior Field Hockey Association**

[www.victoriajuniorfieldhockey.ca](http://www.victoriajuniorfieldhockey.ca)

## **UNDER 10 - LESSON PLAN #8 - NOTES**

---

COACHING NOTES: Review the following coaching notes prior to the day of practice. Use these tips throughout the drills to help kids progress.

### **Indian Dribble**

Progression from stationary:

Have players dribble on the move. The ball will go at a 45 degree angle to the LEFT and to the RIGHT using both the strong and reverse stick.

Encourage players to have smaller taps when moving forward.

*Challenge:* Change of the distance of the tap

### **Passing & Receiving**

Focus: strong stick reception on the move - the pass is into space

X1 and X3 both start with balls. They dribble straight ahead, getting the ball position to 12 o'clock before rolling the ball into space, diagonally LEFT for X2 and X4 to run onto. X2 and X4 dribble and send the ball directly to the lines of X1 and X3. This drill is continuous - pass and follow your pass.

### **Passing & Receiving**

Focus: Upright reverse stick reception on the move. The pass is into space.

Same as above except X1 and X3 need to get their feet around before they make a push pass into space. The ball position will be at about 3 o'clock. X2 and X4 make an upright reverse stick reception - get it to their strong stick right away and then send a pass directly to the lines of X1 and X3.





## 1. Warm-up Game / Agilities

## 2. Dribbling & Passing - Draws LEFT and RIGHT

- (i) Review stationary draws left and right (approx. 2 minutes)
- (ii) Lateral draws between the 25 yard lines. Players will use the cross-over footwork.
  - a. Drawing LEFT --> leading with LEFT shoulder
  - b. Drawing RIGHT --> leading with RIGHT shoulder
- (iii) Diagonal draws LEFT and RIGHT backwards --> 3 draws LEFT, 3 draws RIGHT, repeat over 25 yards (making zig zag shapes)

## 3. Passing & Receiving

Pass and follow your pass.

X1 dribble and diagonal pull back to stornig stick and then sends a square pass to X2. X2 runs on to the ball, timing their lead, and gets their feet around to shield the ball and send a through pass to X3. X3 holds and times their run to pick up the ball over RIGHT shoulder.

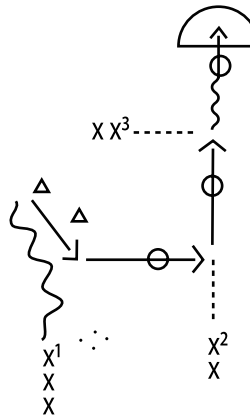

## 4. Passing: Indoor Sweep Pass

- (i) Passing in pairs (about 12-15 yards apart for 2 minutes)
- (ii) See drill diagram below. Follow your pass.

- minimize touches on the ball
- low body position
- passes are about 7 yards in length

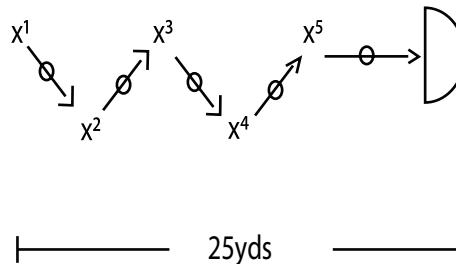

\*\*Keep stick on the ground during pass!

## 5. Skills Game

MINI GAME: make a field about 25 x 30 yards using two cones (1 yard apart) per goal. Have multiple goals spread randomly throughout the grid. Teams can score in any goal just not the same goal twice in a row.

Variations: (1) goal = "shoot" through the cones (2) goal = pass to team mate through cones (3) goal = dribble with control through cones

## 2. COACH TIPS

When going to the reverse stick, the stick should roll in the right hand so that the right wrist does not turn over. The stick spins in the right hand.

## 3. COACH TIPS

On the draw back, remember to drop step with the right foot to be able to open up the stance and see the space the pass is going to go into.

X2 should be in motion on reception and pass. X3 needs to time their lead and get their shot off in as few touches as possible.

## 4. COACH TIPS

Players should pass and follow their pass. Sweep hits should be hard and accurate - more important is accuracy over power. Remind players that the ball position must be right in front of them and in the middle of their body or slightly forward. This drill works on receptions as well!



**Victoria Junior Field Hockey Association**

[www.victoriajuniorfieldhockey.ca](http://www.victoriajuniorfieldhockey.ca)

## **UNDER 10 - LESSON PLAN #9 - NOTES**

---

COACHING NOTES: Review the following coaching notes prior to the day of practice. Use these tips throughout the drills to help kids progress.

### **Passing & Receiving**

X1 minimizes touches on the ball and footwork after the pull back. Ideally, X1 pulls back, using a rocker step and as the weight is on the right foot, the right foot pivots and the left foot comes around to shield the ball before making the pass to X2.

X3 holds their lead until the ball is sent - this way X3 is running onto the pass that is sent into space.

### **Passing & Receiving: Indoor Sweep Pass**

Hands are apart (left hand at top of stick, right hand at bottom of stick grip). Stick angle is the same as a push pass. LEFT shoulder is facing the target. The ball is rolled towards target, the stick is swept along the turf before making contact with the ball.

Follow through points towards target. The contact with the ball is made just slightly behind the LEFT foot.

Drill (ii): make sure the receiver is looking before the pass is made. When the ball is received, either let it cross the body or shield the ball.

Minimize the touches on the ball and footwork before making the next pass.



## 1. Warm-up Game / Agilities

### 2. Dribbling: All skills

- (i) push dribble (ball at 1 o'clock) x 2 minutes
- (ii) dribble & check (2 minutes)
- (iii) indian dribble (2 minutes)
- (iv) Lateral draws (from last week) 2 minutes

Encourage players to start dribbling with their heads up instead of always looking at the ball.

### 3. Passing & Receiving

Pass and follow your pass.

X2 dribbles diagonal pull back to strong stick send a square pass to X2. X2 then runs on to the ball, gets feet around shielding the ball and the ball then gets sent through for X3. X3 holds and picks the ball up over her LEFT shoulder - dribble - curls left and sweeps at goal.

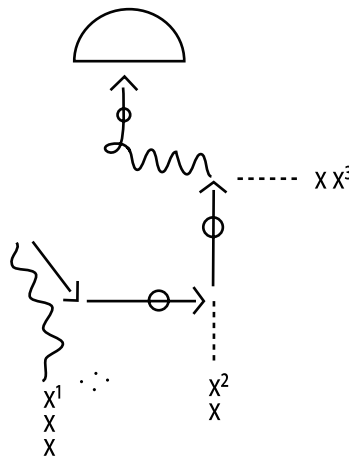

### 4. Defense

Revisit the Channel. Players keeping their sticks on the ground while defending.

- (i) Each player will dribble twice and channel twice
- (ii) repeat having "X" face in the opposite direction
- (iii) Encourage "o" to change directions while dribbling. This way "X" needs to focus on quick feet while keeping "o" in front of her.

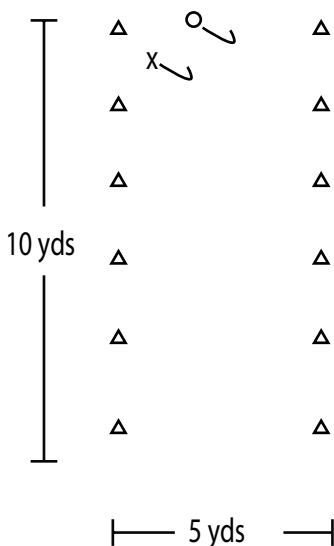

Progressions:

- increase speed of the dribbling
- progress to a 1 vs. 1 situation

### 2. COACH TIPS

Dribbling skills should be done over 15-25 yards in a straight line.

### 3. COACH TIPS

On the draw back, remember to drop step with the right foot to be able to open up the stance and see the space the pass is going to go into.

X2 should be in motion on reception and pass. X3 needs to time their lead and get their shot off in as few touches as possible.

### 5. Skills Game

MINI GAME: make a field about 25 x 30 yards using two cones (1 yard apart) per goal. Have multiple goals spread randomly throughout the grid. Teams can score in any goal just not the same goal twice in a row.

Variations: (1) goal = "shoot" through the cones (2) goal = pass to team mate through cones (3) goal = dribble with control through cones